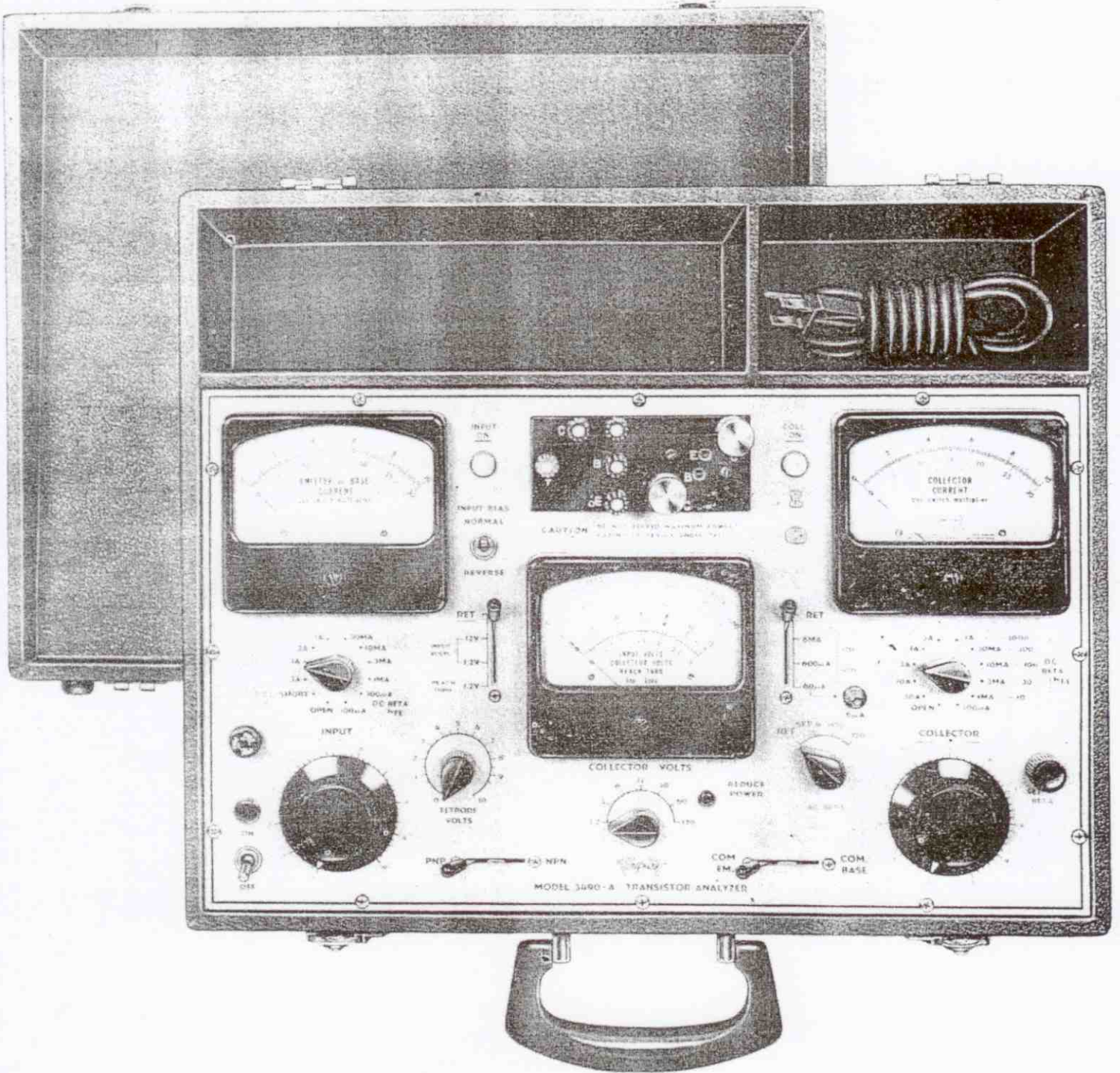

TABLE OF CONTENTS

SUBJECTS	Page
PHOTO MODEL 3490-A	3
Functional Block Diagram Overall	4
TRANSISTOR ANALYZER	5
Control Functions	5
BETA MEASUREMENT	
Block Diagram	6
Step by Step Procedure	7
I_{CO} (I_{CBO})— I_{CEO} MEASUREMENT	
Block Diagram	8
Step by Step Procedure	9
I_{EO} — I_{EBO} MEASUREMENT	
Block Diagram	10
Step by Step Procedure	11
ALPHA MEASUREMENT	
Block Diagram	10
Step by Step Procedure	11
AC BETA MEASUREMENT	
Block Diagram	12
Step by Step Procedure	13
TECHNICAL DESCRIPTION	
The Meters and Range Selectors	13
The Main Controls	14
The Secondary Controls	14
Configuration—Test Index	15
Connections to Transistors	16
— The Heat Sink	17
The Interlocks	17
The Warning Lights	17
DIRECT READING DC BETA— h_{FE}	18
MEASURING SATURATION VOLTAGE AND RESISTANCE	18
MEASURING REACH THRU	18
Floating Potential	19
TETRODE TRANSISTORS	19
TESTING DIODES AND RECTIFIERS	20
Information	20
Testing Diodes	20
Testing Rectifiers	20
Selenium Rectifiers	21
Measurement of SCR Parameters	21
WIRING DIAGRAM	23
REPLACEABLE PARTS LIST	24-25
WARRANTY	26

Copyright 1967

THE TRIPLETT ELECTRICAL INSTRUMENT COMPANY
BLUFFTON, OHIO



Model 3490-A

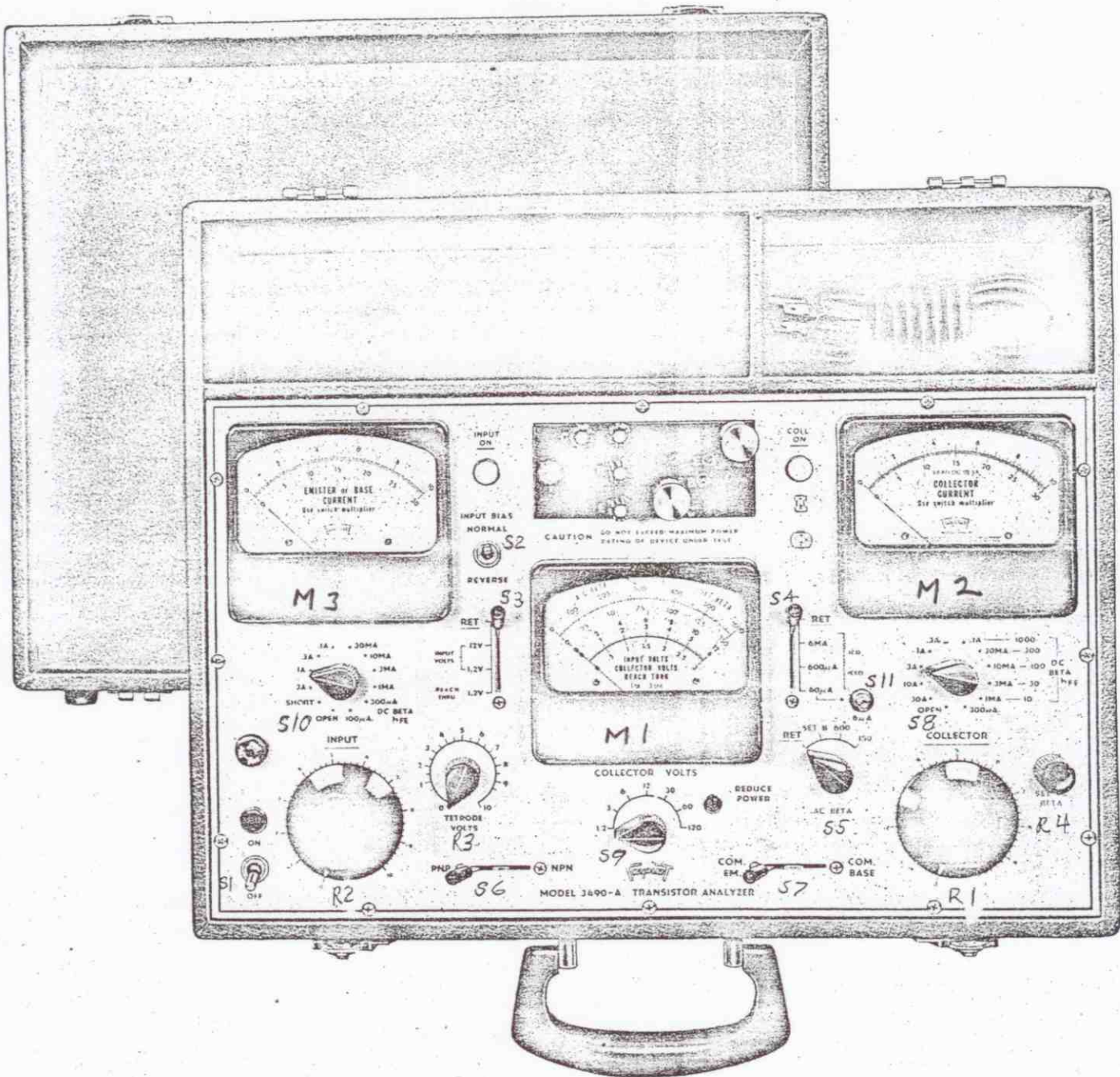

Model 3490-A Type 2

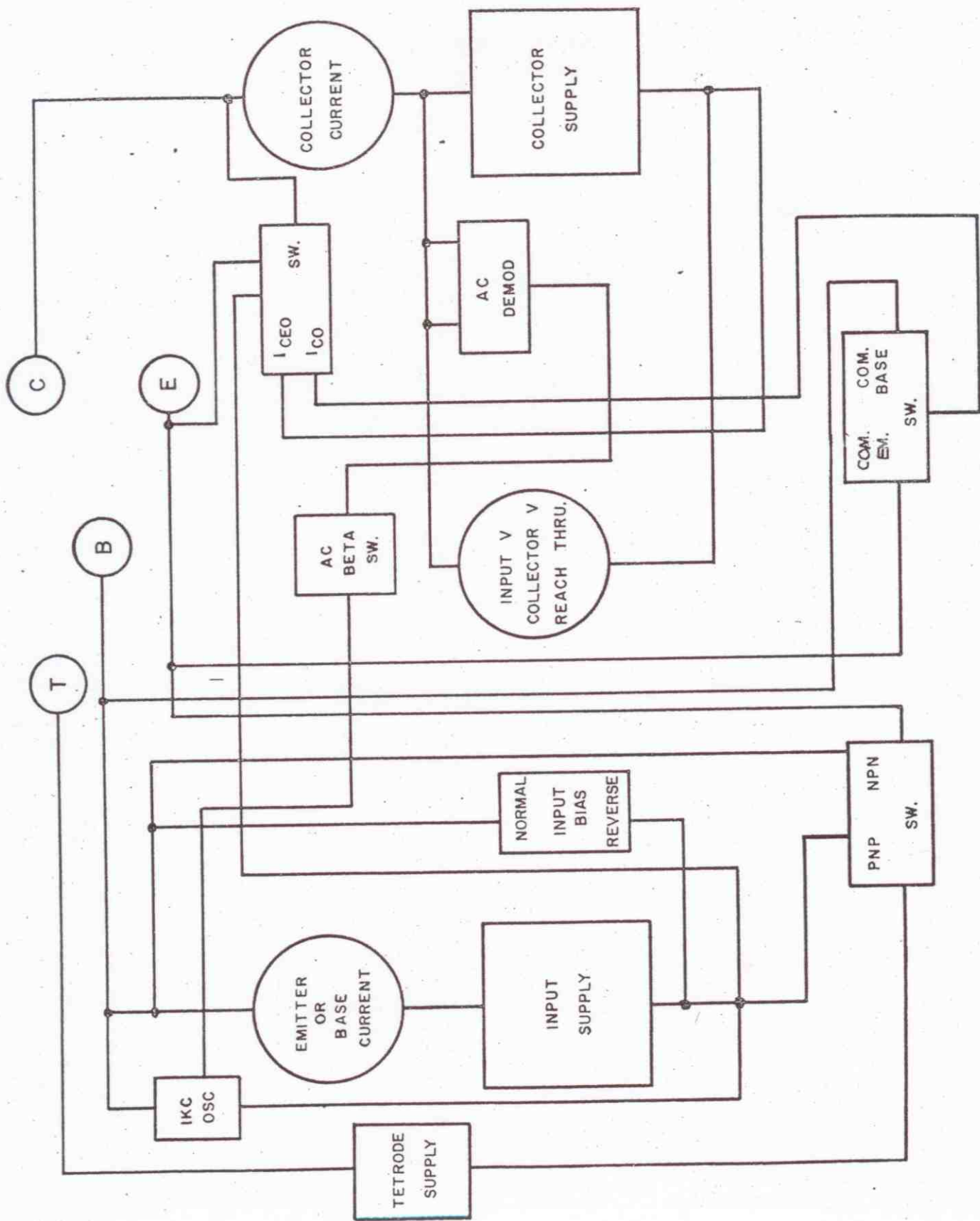

FUNCTIONAL BLOCK DIAGRAM - OVERALL

TRIPLETT TRANSISTOR ANALYZER

Model 3490-A Type 2

This Transistor Analyzer is designed for maximum flexibility, wide coverage of both signal and power transistors, and standard readings of all measurement values in volts, amperes and ohms as listed by the semi-conductor manufacturers. Continuous current and continuous voltage controls are a built in feature, with large accurate meters to read static as well as dynamic values. Interlocked switching circuits with warning

light indicators protect the semi-conductors from voltage transients, while at the same time assisting the operator in the testing procedure. Collector Current and Emitter or Base Current is monitored all the time, and the controls with other instrumentation provide facilities for plotting complete characteristic curves as well as taking single readings.

CONTROL FUNCTIONS

Note—For further detail see technical description and functional block diagrams.

EMITTER OR BASE CURRENT—Meter

This meter monitors input current, either in the common emitter or common base configuration.

INPUT VOLTS, COLLECTOR VOLTS, REACH THRU, I_{CO} , I_{CEO} —Meter

This meter normally monitors the collector voltage supply, but may be switched throughout the circuit depending upon the desired parameter.

COLLECTOR CURRENT—Meter

This meter monitors the collector or output current of the device under test.

PNP-NPN—Switch

Polarity reversal switch for both the Input and Collector supply.

COM. EM. - COM. BASE—Switch

This switch selects the mode or configuration of a particular test.

INPUT VOLTS, REACH THRU—Switch

This switch inserts the INPUT VOLTS, COLLECTOR VOLTS, REACH THRU meter into the input circuit.

I_{CO} , I_{CEO} —Switch

This switch inserts the INPUT VOLTS, COLLECTOR VOLTS, REACH THRU meter into the collector circuit. In this configuration the meter is monitoring leakage current.

COLLECTOR VOLTS—Switch

Range selector switch for V_{CE} (com. emitter) or V_{CB} (com. base).

AC BETA—Switch

Range selector switch for AC Beta.

INPUT BIAS—Switch

Polarity reversal of input supply.

COLLECTOR—Switch

Range selector switch used in conjunction with COLLECTOR CURRENT meter.

INPUT—Switch

Range selector switch used in conjunction with EMITTER or BASE CURRENT meter.

ON-OFF—Switch

Line control switch for instrument power supply.

SET AC BETA—Control

Fine adjustment for the INPUT VOLTS, COLLECTOR VOLTS, REACH THRU, meter. Used in conjunction with the AC BETA Switch.

COLLECTOR—Control

Regulates V_{CE} (com. em.) or V_{CB} (com. base) in conjunction with COLLECTOR VOLT switch.

INPUT—Control

Regulates Tetrode voltage between tetrode terminal and emitter terminal.

INPUT ON—(Yellow) Indicating Light

The illumination of this light indicates that power is being applied to the input circuit.

COLL. ON—(Yellow) Indicating Light

The illumination of this light indicates that power is being applied to the collector circuit.

REDUCE POWER—(Red) Indicating Light

The illumination of this light indicates that an overload condition exists.

ON—(Red) Indicating Light

The illumination of this light indicates that line power is being applied to the instrument.

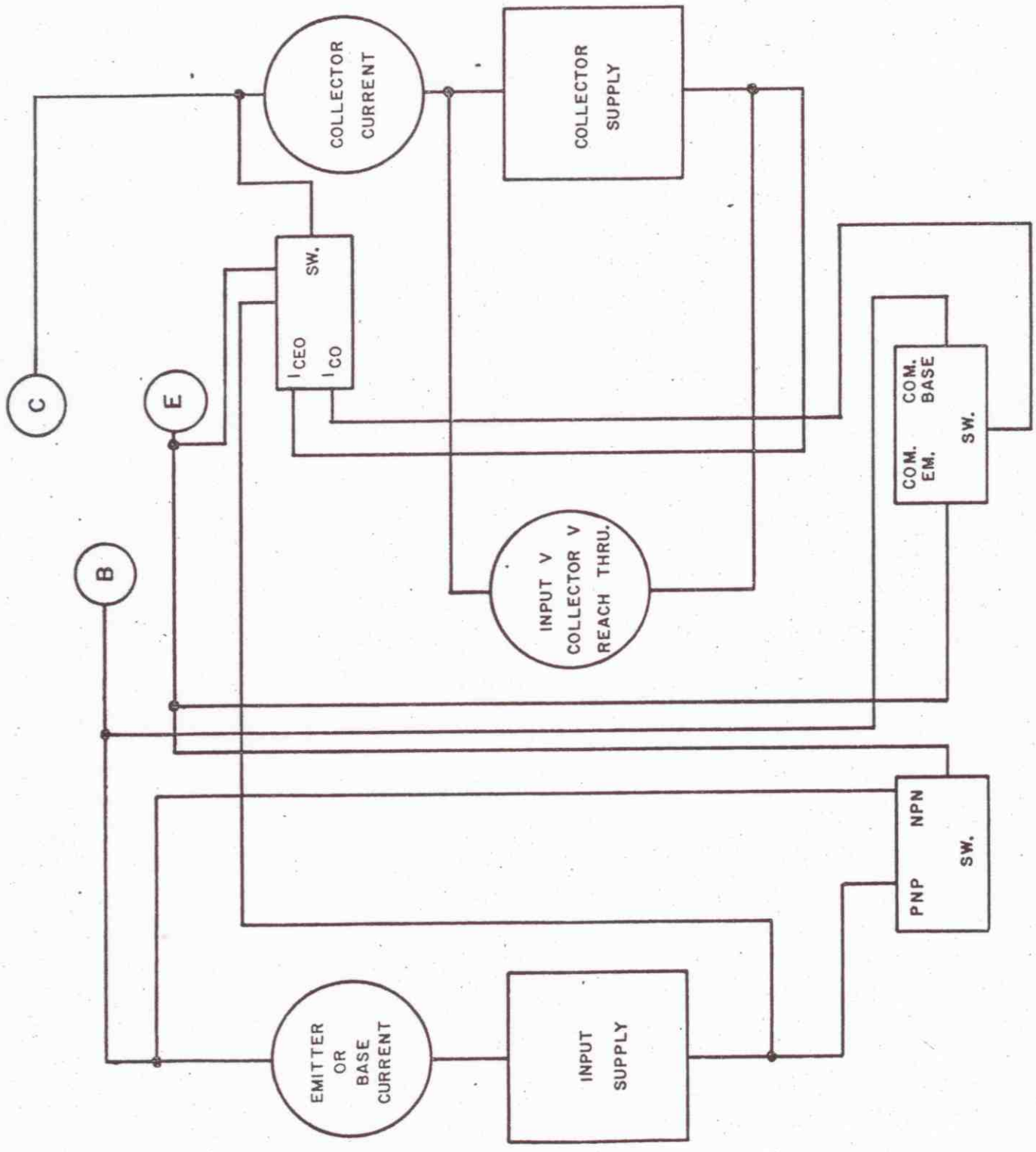

FUNCTIONAL BLOCK DIAGRAM - BETA (h_{FE})

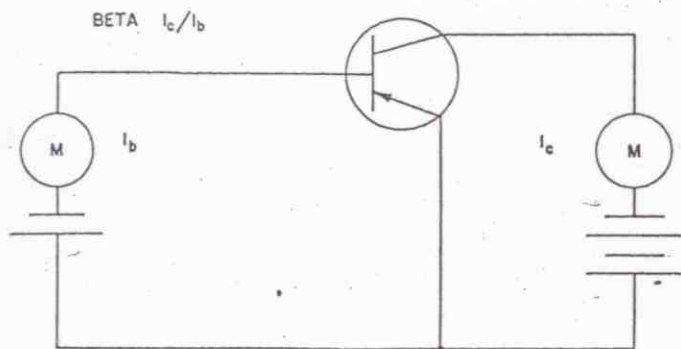

DC BETA (h_{FE})

Refer to the transistor reference book supplied with this instrument to determine the following parameters.

- A.) Transistor type (NPN or PNP)
- B.) Rated h_{FE}
- C.) I_C or I_B at which h_{FE} is listed at the specified V_{CE} .
- D.) P_C max.
- E.) Physical outline

CAUTION—DO NOT EXCEED MAX. RATINGS AT ANY TIME.

1. Rotate all control knobs to "O" or counterclockwise. All switches containing RET should be placed in that position.
2. PNP-NPN switch, index to type as listed in transistor reference book.
3. COM. EM. - COM. BASE—Index to COM. EM.
4. COLLECTOR—Current range switch—Index to proper range, I_C at the rated h_{FE} as per the transistor reference book.
5. INPUT—current range switch—Index to proper range. I_B at the rated h_{FE} as per the transistor reference book. If I_B is not listed, it can be calculated by dividing I_C by h_{FE} .
6. COLLECTOR VOLTS—Index to the proper range for V_{CE} as specified in the transistor reference book. The lower limit of V_{CE} is determined by V_{sat} of the transistor under test. The upper limit of V_{CE} is determined by P_c max. of unit under test.
7. Rotate COLLECTOR control knob C.W. until desired V_{CE} is indicated on the COLLECTOR VOLTS meter. The COLL. ON light will illuminate.
8. Rotate the INPUT control knob C.W. until the desired I_C is indicated on the COLLECTOR CURRENT meter. Upon application of current both the EMITTER OR BASE CURRENT meter and the COLLECTOR CURRENT meter will move up-scale. Also, the INPUT ON light will illuminate. If necessary re-adjust V_{CE} .
9. Read the COLLECTOR CURRENT meter and divide this reading by the reading on the EMITTER OR BASE CURRENT meter. This is the BETA of the unit under test. $B = I_C / I_B$.

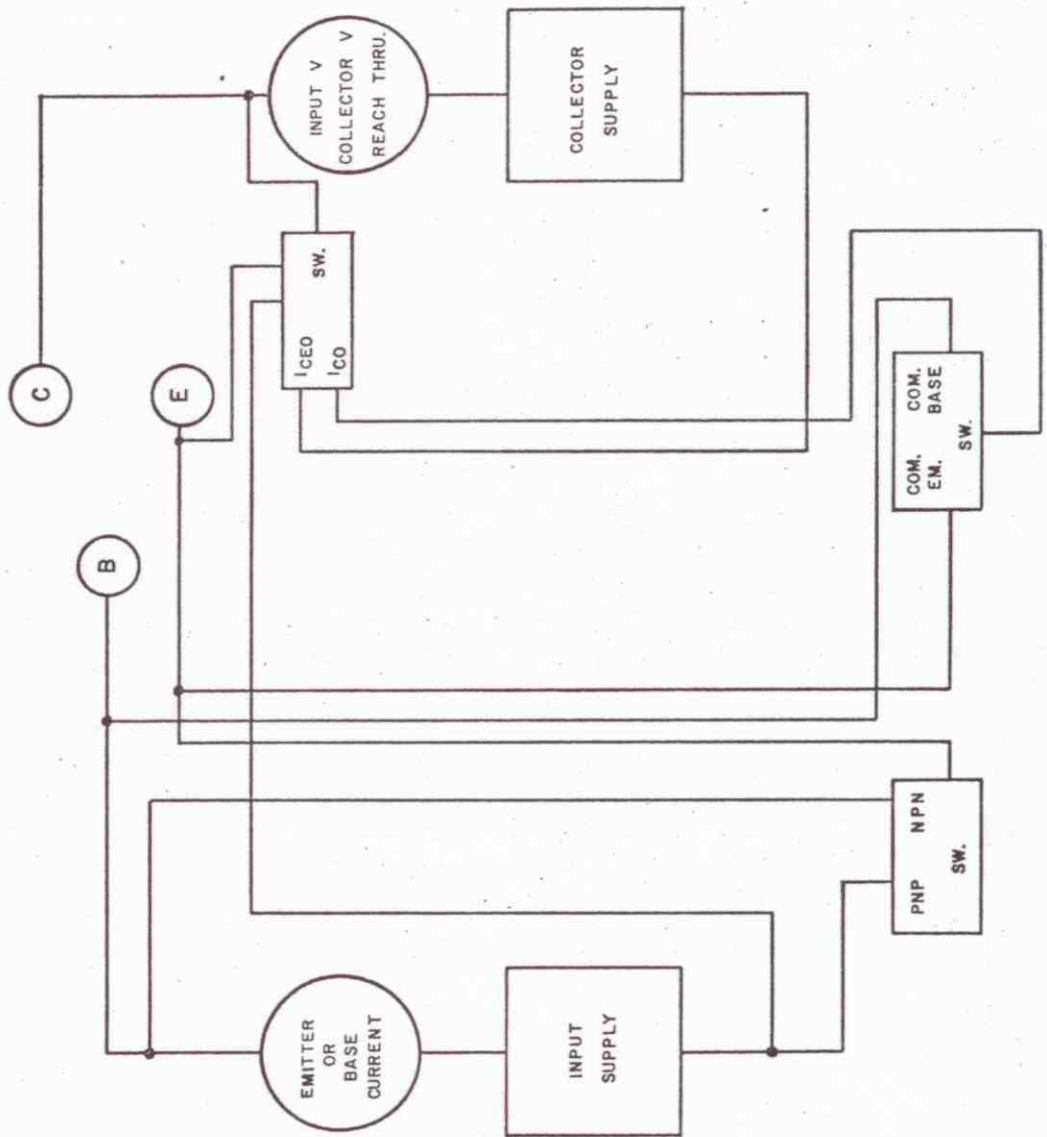

FUNCTIONAL BLOCK DIAGRAM - $I_{CO} (I_{CBO}) + I_{CEO}$

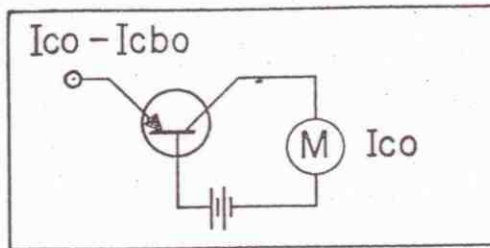

I_{CO} (I_{CBO})

Refer to the transistor reference book supplied with this instrument to determine the following parameters.

- A.) Transistor type (NPN or PNP)
- B.) Rated I_{CBO} at V_{CB}
- C.) Physical outline

CAUTION—DO NOT EXCEED MAX. RATINGS AT ANY TIME

Note— I_{CBO} measurements are taken with the emitter lead disconnected which is accomplished automatically by indexing the I_{CO} , I_{CEO} switch.

1. Rotate all control knobs to "O" or counterclockwise. All switches containing RET should be placed in that position.
2. PNP-NPN switch, index to type as listed in transistor reference book.
3. COM. EM. - COM. BASE—Index to COM. BASE.
4. COLLECTOR VOLTS—Index to range as specified for V_{CB} .
5. Rotate COLLECTOR control knob C.W. until desired V_{CB} is indicated on the COLLECTOR VOLTS meter.
6. Index the I_{CEO} , I_{CO} switch to the desired range. The leakage current is monitored on the COLLECTOR VOLT meter, 0-6 scale.

Note—If the leakage current of the unit under test is higher than 6 MA, leave the I_{CEO} , I_{CO} switch in the RET position and read the current on the COLLECTOR CURRENT meter. The INPUT range switch must be indexed to the OPEN position.

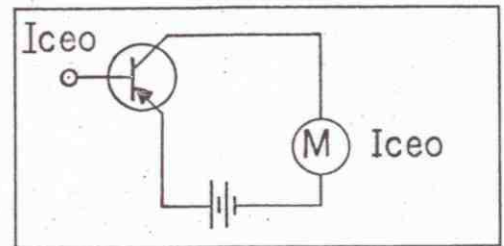

I_{CEO}

Refer to the transistor reference book supplied with this instrument to determine the following parameters.

- A.) Transistor type (NPN or PNP)
- B.) Rated V_{CE}
- C.) Physical outline

CAUTION—DO NOT EXCEED MAX. RATINGS AT ANY TIME

Note— I_{CEO} measurements are taken with the base lead disconnected which is accomplished automatically by indexing the I_{CO} , I_{CEO} switch.

1. Rotate all control knobs to "O" or counterclockwise. All switches containing RET should be placed in that position.
2. PNP-NPN switch. Index to type as listed in transistor reference book.
3. COM. EM. - COM. BASE—Index to COM. EM.
4. COLLECTOR VOLTS—Index to range as specified for V_{CE} .
5. Rotate COLLECTOR control knob C.W. until desired V_{CE} is indicated on the COLLECTOR VOLTS meter.
6. Index the I_{CEO} , I_{CO} switch to the desired range. The leakage current is monitored on the COLLECTOR VOLTS meter, 0-6 scale. Note—If the leakage current of the unit under test is higher than 6 MA, leave the I_{CEO} , I_{CO} switch in the RET position and read the current on the COLLECTOR CURRENT meter. The INPUT range switch must be indexed to the OPEN position.

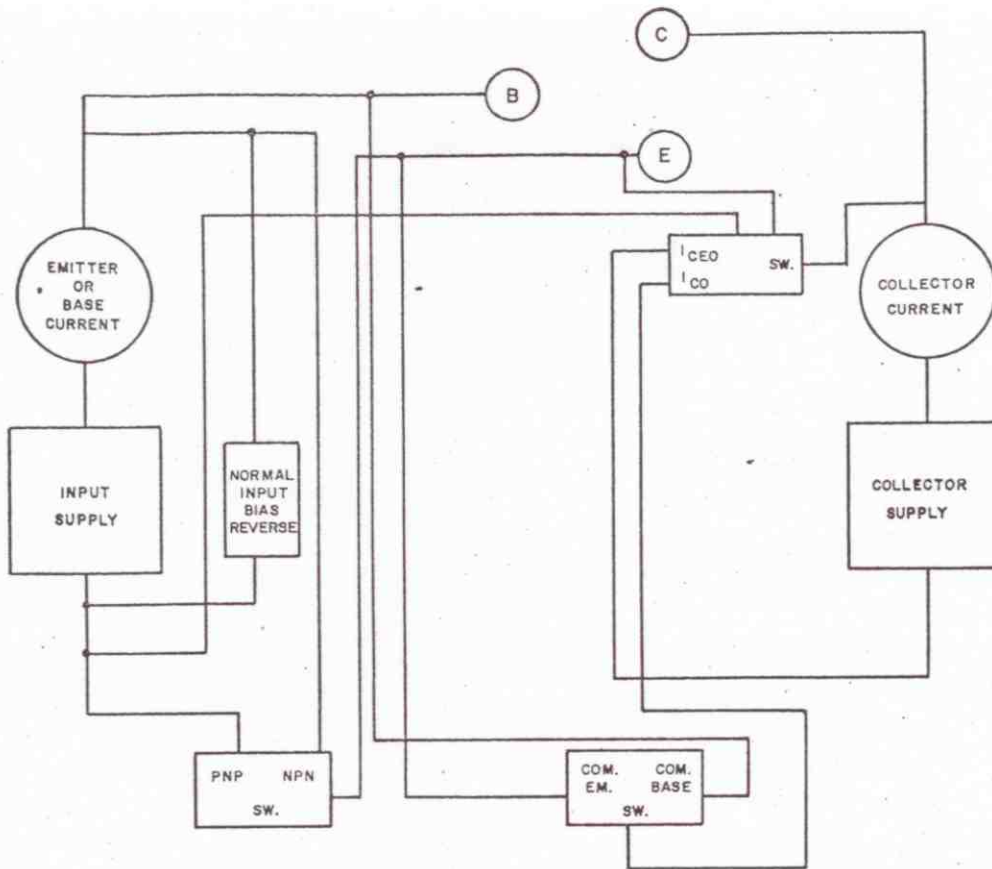

FUNCTIONAL BLOCK DIAGRAM - I_{EO} (I_{EBO})

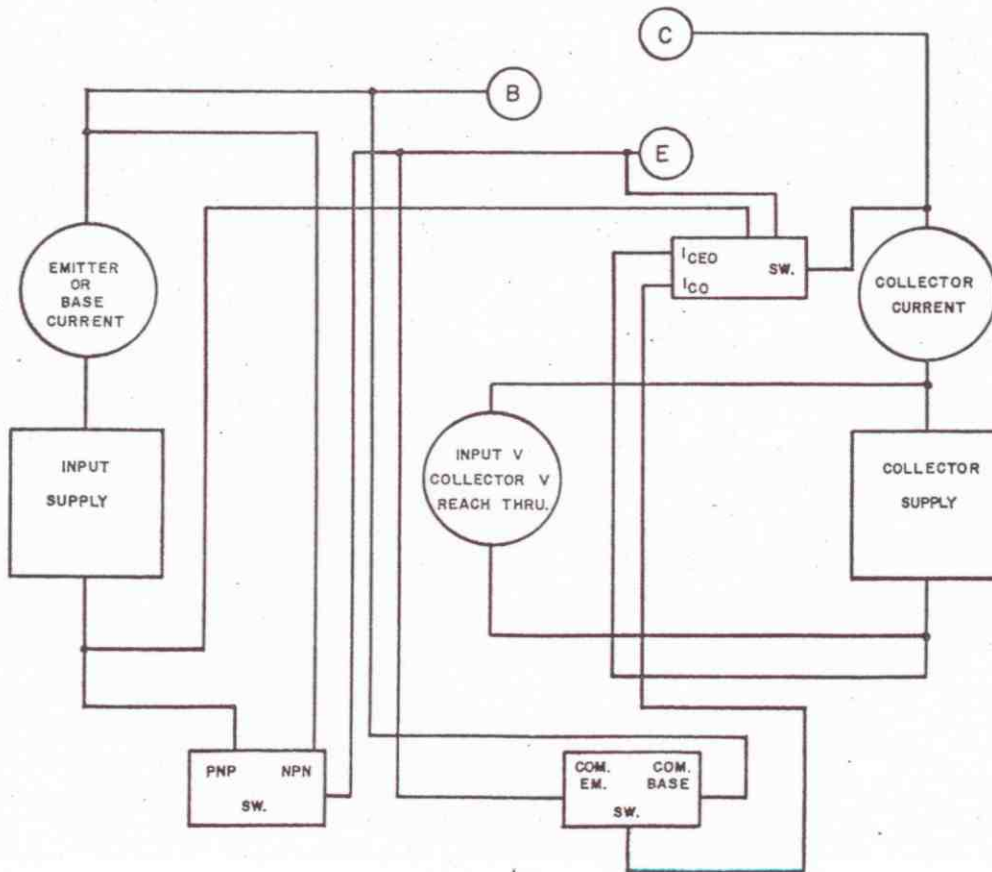

FUNCTIONAL BLOCK DIAGRAM - ALPHA (h_{FB})

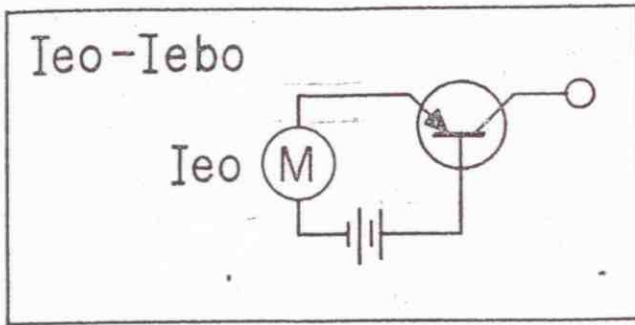

I_{EO} (I_{EBO})

Refer to the transistor reference book supplied with this instrument to determine the following parameters.

- A.) Transistor type (NPN or PNP).
- C.) Physical outline.
- B.) Rated V_{EBO} or V_{EB} @ I_{EO} (I_{EBO})
- C.) Physical outline.

CAUTION—DO NOT EXCEED MAX. RATINGS AT ANY TIME

Note— I_{EO} (I_{EBO}) measurements are taken with the collector lead disconnected. This is accomplished by

placing the COLLECTOR current range switch to the OPEN position.

1. Rotate all control knobs to "O" or counterclockwise. All switches containing RET should be placed in that position.
2. PNP-NPN switch—Index to the type as listed in the transistor reference book.
3. COM. EM. - COM. BASE—Index to COM. BASE.
4. INPUT BIAS—Index to REVERSE position.
5. INPUT VOLTS—Index to desired range.
6. INPUT current range selector—Index to desired range.
7. Rotate the INPUT control knob to give the desired voltage between Emitter and Base as indicated on the input voltmeter.

Read the leakage current I_{EBO} on the input current meter.

(Note) Return Input bias switch to normal after test.

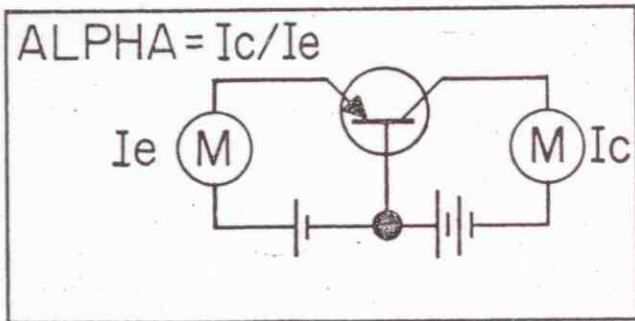

ALPHA (h_{FB})

Refer to the transistor reference book supplied with this instrument to determine the following parameters.

- A.) Transistor type (NPN or PNP).
- B.) Rated h_{FB} ($h_{FB} = I_c / I_e = B / B + 1$) @ V_{CB}
- C.) Physical outline.

CAUTION—DO NOT EXCEED MAX. RATINGS AT ANY TIME

1. Rotate all control knobs to "O" or counterclockwise. All switches containing RET should be placed in that position.
2. PNP-NPN switch—Index to type as listed in transistor reference book.
3. COM. EM. - COM. BASE—Index to COM. BASE.
4. COLLECTOR—Current range switch—Index to proper range for I_c .
5. INPUT—Current range switch—Index to proper range for I_e .
6. COLLECTOR VOLTS—Index to proper V_{CB} .
7. Rotate the COLLECTOR control knob to a V_{CB} value as specified.
8. Rotate the INPUT control knob to desired value of I_c . The COLLECTOR current meter will move up-scale as the INPUT knob is rotated. Divide the reading on the COLLECTOR CURRENT meter by the reading on the EMITTER OR BASE CURRENT meter. This is ALPHA.

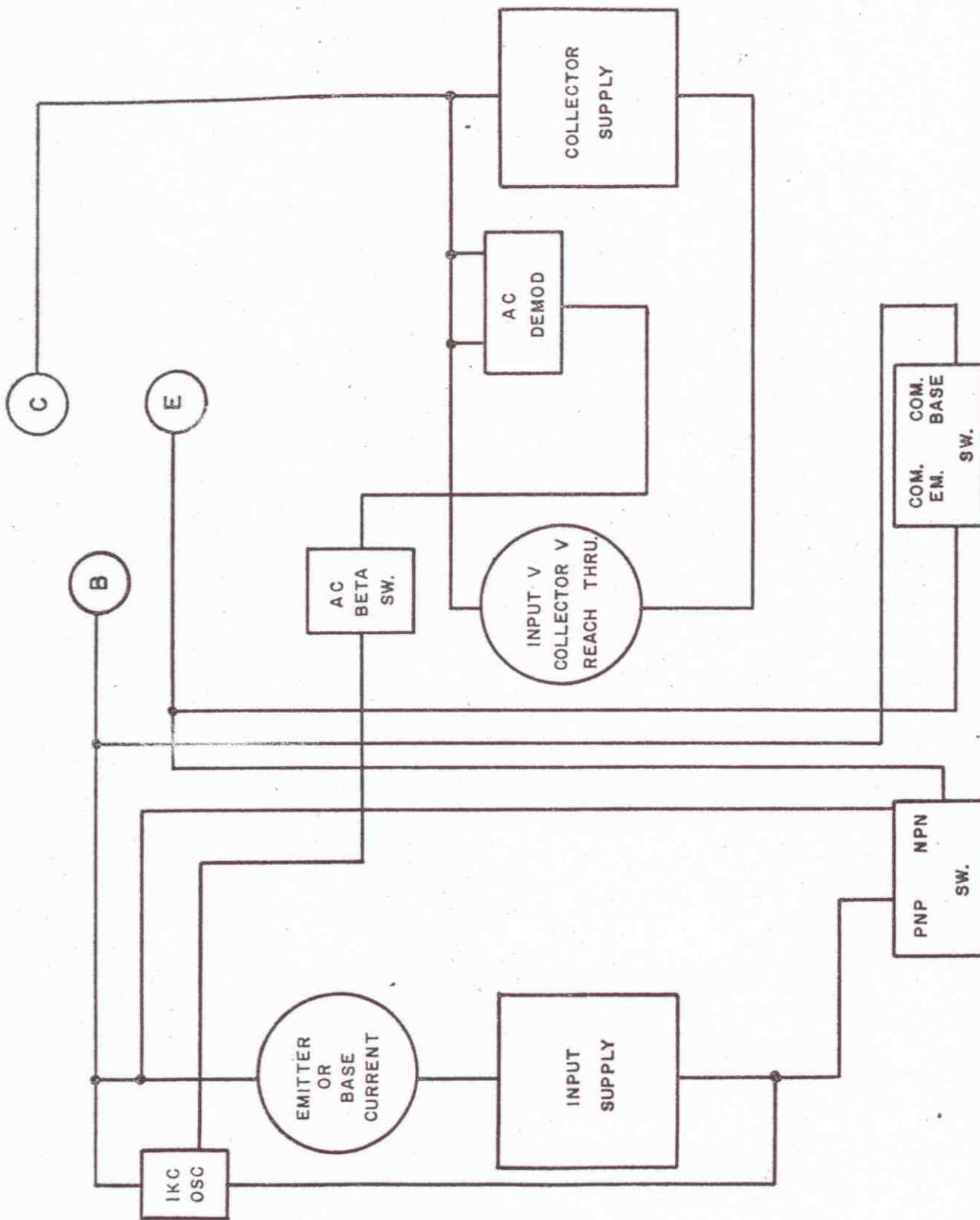

FUNCTIONAL BLOCK DIAGRAM - A.C. BETA (h_{fe})

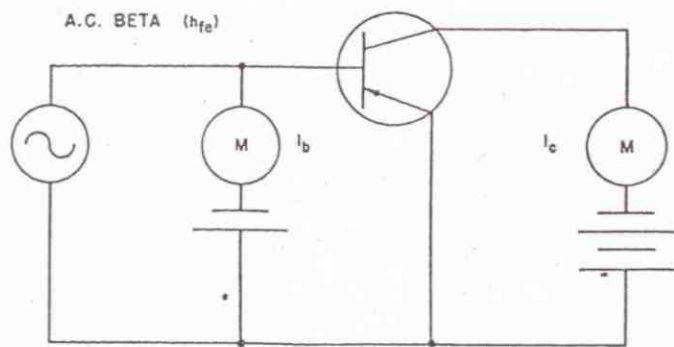

AC BETA (h_{fe})

Refer to the transistor reference book supplied with this instrument to determine the following parameters.

- A.) Transistor type (NPN or PNP).
- B.) Rated h_{fe}
- C.) Physical outline.

CAUTION—DO NOT EXCEED MAX. RATINGS AT ANY TIME

1. Rotate all control knobs to "O" or counterclockwise.

All switches containing RET should be placed in that position.

2. PNP-NPN switch—Index to type as listed in transistor reference book.
3. COM. EM. - COM. BASE—Index to COM. EM.
4. COLLECTOR—current range switch—Index to desired range.
5. COLLECTOR VOLTS—Index to specified range for V_{CE} .
6. Rotate the INPUT and COLLECTOR control knobs until the desired V_{CE} , I_B and I_C are obtained.
7. AC BETA—switch—Index to the SET B position.
8. Rotate the SET BETA control knob to bring the pointer of the INPUT VOLTS, COLLECTOR VOLTS, REACH THRU, meter to the SET AC BETA mark.
9. Index the AC BETA switch to the 600 or 150 position and read the corresponding BETA on the red arc.

TECHNICAL DESCRIPTION

THE METERS AND RANGE SELECTORS:

Transistors are inherently current sensitive devices as compared to vacuum tubes which are primarily voltage sensitive. Current readings and current amplification values are therefore, the important guiding factors in transistor evaluation. It is of utmost importance to know the Collector Current at all times, regardless of the parameter under measurement. This Transistor Analyzer is equipped with a four and one half inch multirange ammeter which reads continuously the Collector Current on any one of 11 overlapping ranges. This meter is located in the upper right hand corner of the panel. The scale captioned "Collector Current" has two arcs; the outside one calibrated from zero to thirty, and the inside one from zero to ten. All of the current ranges are on a zero-ten and zero-thirty basis, from 1 milliamperes to 30 amperes, and therefore, on any range it is necessary only to add zero's to the scale reading, or divide by ten to determine the exact Collector Current. As you will note, the high ampere range on the 3490-A is 30 amperes. Care in operation of the Analyzer on this range is imperative. The 3490-A is designed to handle over 100 D.C. volt-amperes of collector power. However, due to the heat characteristics which occur when this type of power is used, it is recommended that readings on this range should not exceed 45 seconds for any one reading.

When using the 3490-A at the higher collector current values, it is recommended that for each 15 minutes continuous testing, it be allowed a similar period of cooling time to prevent a heat build-up in the components. The Collector Current range selector switch

is mounted directly below the Collector Current meter providing in combination an effective and accurate milliammeter and ammeter accurate to within $\pm 2\%$. In addition to the current ranges, this switch can be set to the "Open" position, which is used when taking emitter readings under conditions where the collector must be open in respect to the base.

Since this Transistor Analyzer has been designed to measure three or four terminal units in either the Common Base or Common Emitter configuration, the Input Current can be introduced or applied thru either the Emitter or Base. Accordingly, this meter is labeled "Input Current", and is mounted in the upper left hand corner of the panel. It reads Emitter Current when the Common Emitter-Common Base lever switch is in the Common Base position, and when the switch is indexed to the Common Emitter position, the Input meter reads Base Current. It was stated before and repeated here that transistors are current amplifying devices, and therefore, this meter is connected to read Input Current **all the time**. Like the Collector Current meter, the Input Current meter has the same two arcs numbered zero to thirty. Continuous coverage is available from zero to ten and zero to thirty. Continuous coverage is available from 100 microamperes full scale to 3 amperes full scale, accurate to within $\pm 2\%$. Again it is necessary only to add zero's or divide by ten to obtain the exact emitter or base current applied to the transistor. Also, the Input Current range selector switch is mounted directly below the Input meter for operational convenience. In addition to the current ranges, this switch can also be set to "Open" and "Short" positions, which are used when taking collector readings under conditions

where either the emitter or the base must be open or short-circuited to the collector circuit. It was stated before that the Collector meter reads Collector Current at all times, and that the Input meter reads Input Current all of the time. Therefore, the operator of the Transistor Analyzer has in front of him the two most important functional values on continuous display. Thus, by comparing the Input or Emitter Current and the Collector Current in the Common Base configuration, the value of alpha or forward current transfer ratio h_{FB} can be determined. By comparing the ratio between Collector Current and the Input or Base Current in the Common Emitter configuration, the value of d-c Beta or forward current transfer ratio h_{FE} is determined.

The third meter in the approximate center of the panel reads Collector Voltage all the time unless it is being used for some special function, such as α -c Beta, I_{CO} , I_{CEO} , Input Voltage or Reach Thru. Seven voltage ranges with about a 2-1 ratio are calibrated on the black or d-c arcs figured zero to 3, zero to 6 and zero to 12. For the 30, 60, and 120 volt ranges it is again necessary only to add a zero to the meter reading, and for reading the 1.2 volt range, it is necessary to drop a zero. These voltage ranges are available by using the Collector Volts range selector switch directly below the meter. The combination of the range switch and the Collector Volts meter gives the operator continuous control of the Collector voltage through 120 volts accurate to $\pm 2\%$. The use of the three meters presents to the operator a completely flexible operational analysis of the transistor under test. Collector Current can be plotted as a function of Base Current by holding the Collector Voltage constant—Collector Current can be plotted against Collector Voltage—Saturation Voltage or resistance can be measured, etc.

The scale arcs figured in red on the center meter are calibrated for the α -c Beta or h_{FE} readings, and are used for this measurement on low power or signal transistor types. The range of α -c Beta is determined by the position of the α -c Beta rotary switch which is located at the lower right of this meter.

THE MAIN CONTROLS:

The main controls are set up on the panel to enable the operator to most conveniently explore the transistor characteristics and/or plot characteristic curves. There are three independent power supplies in the analyzer, namely, the collector supply with its control knob directly under the word "COLLECTOR", the input supply, with its control knob under the word "INPUT", and the tetrode supply with its control calibrated zero to 10 volts and marked "TETRODE VOLTS". The Collector control is a variable transformer controlling primary energy to the collector supply. The Input control is a vitreous power potentiometer for adjusting the secondary a-c voltage to the input supply. These are the two most important controls, and are equipped with the large knobs for convenience of adjustment. The numbered arcs around the edge of the control knobs are for reference only, and are to assist the user for referring to a previously metered voltage on the center meter, when that meter has been switched from that circuit for other measurement purposes. **They should always be returned to the extreme counter clockwise position before connecting a transistor for test.** The

Tetrode control is used only for double base or tetrode transistors, and is used only when testing these types.

THE SECONDARY CONTROLS:

To the far lower left of the panel the tester power "On-Off" group is located. This consists of the ON-OFF switch, the on-off indicator lamp, and the power line fuse.

The INPUT current range switch and control have been previously discussed. These operate together for adjustment of the base or emitter current as desired.

Along the left side of the Collector Voltmeter is located a lever switch with the wording "RET", "Input volts", and "Reach Thru". This is one of the three switches used for shifting circuits and for connecting the meter in the center of the panel into the required position. The "RET" is the panel abbreviation for "Return" and it is important that this switch be left in the "RET" position, except when taking the "Input Voltage" readings, or "Reach Thru" voltage readings, and then returned to the "RET" position before proceeding with any other tests. This lever switch may be indexed into the 12 volt input volts position, or into the 1.2 volt input position. Thus, in these two positions, the meter reads the input voltage directly at the emitter and base terminals from zero to 1.2 volts, or zero to 12 volts. If the Transistor Analyzer is set up for the common base configuration, the meter will read the voltage from the emitter to the base and collector return. Likewise, if it is set up in the common emitter configuration, the meter will read the voltage from the base to the emitter and collector return. In the "Reach Thru" position, the meter will indicate the voltage from the open emitter to the base, and as is marked on the panel, indicating voltage from zero to 1.2 volts on the Collector Voltmeter.

Directly above this lever switch, and to the right of the Input Current Meter, you will note a toggle switch with the panel markings INPUT BIAS, and that it may be indexed to NORMAL or REVERSE positions. This switch for most test applications must be in the NORMAL position. For convenient testing of some transistors and parameters, however, the Input current must have opposite or reverse polarity, thus making a reversed bias junction of the emitter-base junction. When this is necessary, it may be done merely by indexing the toggle switch to the REVERSE position. This switch in no manner changes the polarity of the collector circuit. CAUTION: Always make sure this switch is in the NORMAL position, except for making the above mentioned special tests. Damage to the emitter-base junction could result if this junction is not properly biased. Also, good transistors would test defective with improper use of this switch.

The lever switch along the right side of the Collector Voltmeter is used for all measurements of I_{CO} , I_{CEO} and related leakage tests. This is the second of the three circuit shifting switches. You will note the "RET" position on this switch, which is, as on the Input Volts switch, in the uppermost position. This switch also **must** be indexed to the "RET" position except when taking I_{CO} , I_{CEO} , and related leakage tests, and immediately returned to the "RET" position. Since this analyzer handles high power transistors ranging into several amperes as well as the low power signal types, wide coverage of the leakage currents is required. The four

main leakage ranges are controlled by this lever switch, all of which are read on the 0-60 scale on the Collector Volts meter when the lever is pulled. The 6 ma, 600 μ a, and the 60 μ a ranges are indexed directly by the lever switch. For the last decade the lever switch is left in the 60 μ a position and the 6 μ a push button switch is depressed. Since this is a progressive switch, and an unknown quantity is under measurement, the lever may be moved one step at a time until a suitable reading has been taken. If the indication on the meter is less than ten percent of full scale value, the lever switch may be indexed to the next decade down. This observation will prevent overloading of the current range and thus prevent pointer and meter damage. With the four decades, leakage currents from one hundred nanoamperes (.1 μ a) to six milliamperes may be read. NOTE: Occasionally you may find a transistor which has a higher leakage than it is possible to read on the 6 ma range. To read the leakage on this transistor, index the lever switch to the RETURN position, and index the Collector Current Selector Switch to the range where the deflection is the furthest upscale. As you will remember from the Collector Current Meter discussion on page 3, this meter reads collector current at all times, thus the higher leakage values you may read directly on the Collector Current Meter.

Directly below this lever switch, and to the lower right of the Collector Voltmeter, is the "A. C. BETA" switch. This is the third circuit shifting switch, and as noted on the two lever switches, must be in the "RET" position except when set to perform its own specific test. These three controls may be used **one at a time** for measurements; however they are electrically interlocked, and each switch after use **must** be indexed back to the "RET" (Return) position before using any of the others. In making A. C. Beta measurements, this switch is first set to the "Set B" position, and the meter is then adjusted to the "Beta Set" mark on the dial as was explained in the section which describes use of the 'A. C. Beta' control. Once this adjustment has been made, the switch may be indexed to the 600 or 150 range and the A. C. Beta reading taken directly from the two top red arcs on the Collector Voltmeter. It should be remembered that a-c forward gain characteristics depend on d-c applied values. One of the very useful advantages of this analyzer is that variations in a-c Beta can be noted over a wide range of d-c conditions by observing the three meters operating simultaneously. Thus, h_{fe} can be plotted against I_c or I_b and/or V_c . NOTICE: This A. C. Beta range is operative only when the Collector Current switch is indexed to the .1A or lower ranges, and is thus limited to transistors which have a collector current requirement of .1 ampere or below.

Along the bottom edge of the panel, is the PNP-NPN lever switch. This switch controls the polarity of all potentials applied to the transistor or diode under test, and should be indexed correctly according to the manufacturer's data before making any connections to the semi-conductor device.

Next, to the right is the "Collector Volts" switch. This determines the range of the meter directly above it and also does some power supply switching. The 1.2, 3, 6 and 12 volt dc ranges of Collector Volts are equipped to deliver high current, as may be required for power transistors, and of course are also used for the

signal types. These four positions, 1.2, 3, 6, and 12 are the "high current" positions. In general, for power transistors the 1.2, 3, or 6 volt meter range is adequate and should be used for those measurements requiring the full current rating of the transistor. Other measurements such as I_{CO} , I_{CEO} , Reach Thru, etc. where higher potentials may be required, call for comparatively low current requirements and can be made on 30, 60 and 120 volt ranges. Although the same high power rectifiers are used on all voltage ranges, lower power higher voltage transformer windings are used on the three top voltage ranges, and current should be limited to about 300 milliamperes. Hence, the operator should consider the three top voltage ranges, the "Low Current" ranges, and the four low voltage positions, ie. 1.2, 3, 6 and 12 the "High Current" ranges.

CAUTION: When measuring high collector voltages (120V range) do not return to low voltage ranges until the charged filter capacitor discharges to a value that will not overload the meter.

CONFIGURATION—TEST INDEX

To the right of the "Collector Volts" switch is the "Common Emitter"—"Common Base" lever switch. This must be indexed for the configuration required. For the various measurements it should be indexed as follows:

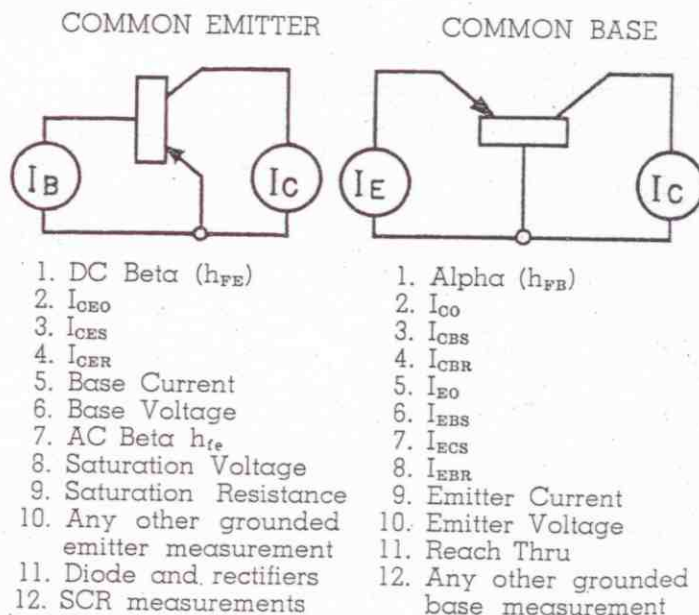

The Collector control and Current range switch have been described before. These operate together for the adjustment of the Collector Current as described. At the far right side of the panel you will see the SET AC BETA control. This is used in conjunction with the AC BETA switch, and is to adjust the 1000 cycle injection current to the proper value prior to the measurement of AC Beta. This value is indicated by the "Set Beta" mark, which is above the top red arc on the center meter. This control, along with the other front panel components are distinguished from the DC controls by the use of red figures on the panel and dial.

CONNECTIONS TO TRANSISTORS:

In the top center section of the panel are mounted two transistor sockets, to the right of the copper heat sink. One of these is for the in-line types where the leads emerge from the bottom of the transistor in a straight line (see Fig. 1). The second socket is for types such as where the leads are grouped in a circle or square on the bottom of the transistor (see Fig. 2).

Nomenclature for socket terminals is as follows:

C—Collector
S—Ground or Shield
B—Base
E—Emitter

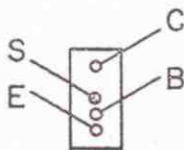

Fig. 1

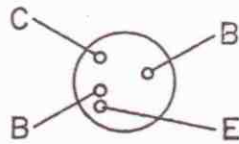
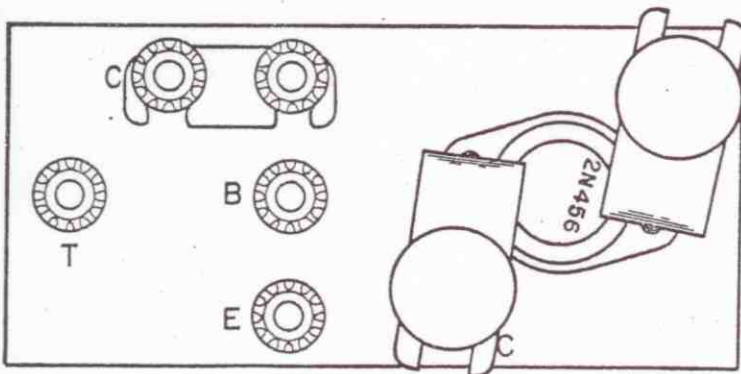

Fig. 2

Aside from these two sockets, binding posts are available on the solid copper bar heat sink. The two large collector posts are mounted on and connect to the copper slab, which is insulated from the panel. These posts are in turn connected to the upper-most black binding post. This binding post in turn usually is connected to black binding post to its immediate left by the linking bar between these terminals. NOTE: WHEN USING ANY OTHER COLLECTOR BINDING POSTS, THE JUMPER CLIP MUST BE ACROSS THESE UPPER TWO BLACK BINDING POSTS FOR CONNECTION TO THE HEAT SINK OR THE TWO LARGE BRASS BINDING POSTS. There may be occasions which require breaking the collector circuit to insert resistors or other components, and this may be done by removing this shorting bar and placing the component between these two black binding posts. Directly below this pair is the middle black binding post, and is the base connector. Below it is the black emitter binding post connector, and at the left of the copper heat sink is the red binding post for the b_2 or tetrode connection. For positive identification, the initials of these transistor elements is engraved beside the corresponding binding posts.



A socket for one of the most commonly used type of power transistor, the JEDEC outline TO-3, is built into the copper heat sink. Power transistors of this type, such as the 2N456 and 2N301, have emitter and base pins extending from the bottom flange, and these fit into the two small holes (which are engraved "E" and "B") between the two collector posts. The mounting flange fits flush against the heat sink, and two "L"

shaped clamps hold the transistor tight against the copper. This also provides the collector current connection. The full required collector current can then be applied to these power types without excessive heat rise in the temperature.

Types such as the 2N101 may be mounted with screw stud on one of the collector posts, with the base and emitter leads either fastened directly or with extension clip leads furnished with the Model 3490-A.

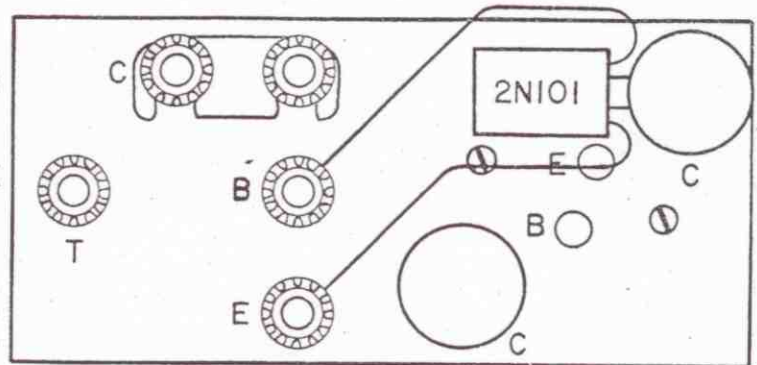

Types such as the 2N443 and 2N1099 are mounted upside down with the slotted clamping plate fastened under the two collector posts. The collector connection is made through the clamping plate. Lead connections are then made from the Emitter and Base binding posts to the emitter and base terminals on the transistor. The short heavy leads which are included with the 3490-A are for this purpose.

CAUTION: IN CLAMPING THIS TYPE OF TRANSISTOR INTO PLACE, MAKE SURE THAT THE EMITTER AND BASE TERMINALS ARE NOT MAKING CONTACT WITH THE CLAMP.

CAUTION: THE MAXIMUM SAFE POWER WHICH MAY BE APPLIED TO A TRANSISTOR USING THIS CLAMPING DEVICE IS APPROXIMATELY 12 VOLT-AMPERES. FOR TESTING AT HIGHER POWER RATINGS, IT IS IMPERATIVE THAT A HEAT SINK DESIGNED FOR THIS PURPOSE BE USED, SUCH AS ARE RECOMMENDED BY THE MANUFACTURERS OF THE POWER TRANSISTORS.

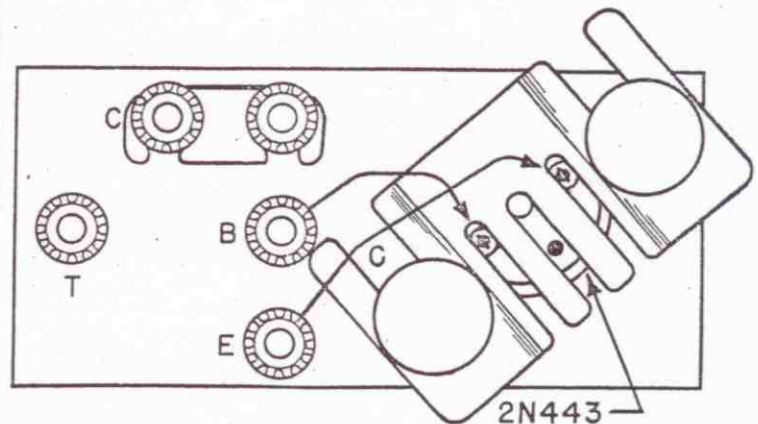

Where other types may be involved one of these combinations should provide sufficient thermal conductivity for any of the power types. If required, an external fitting may be used with leads fastened to the

binding posts. A compartment is provided for such a device to the left rear of the connector block in the case.

On the signal types with long leads, it often saves time to connect the leads directly to the binding posts rather than insert them into the small sockets. For added convenience in testing long lead transistors you will note the binding posts for the emitter, base, and collector are in a line, and spaced for standard transistor plug-in devices.

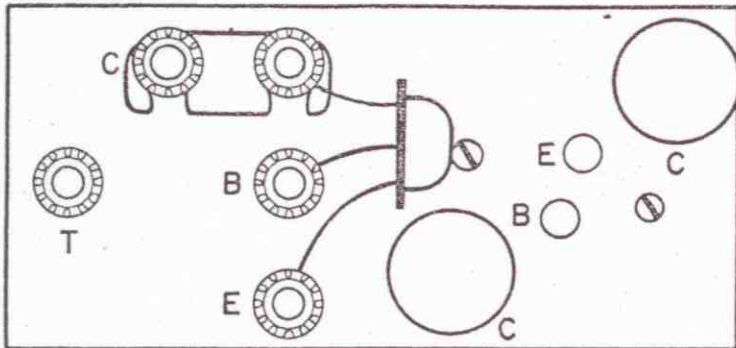

Where a transistor is equipped with a ground lead, this may be connected to the emitter post. On double base or tetrode units, the b2 terminal is connected to the red binding post. An example of this type is the 3N36.

THE HEAT SINK:

The solid slab of copper on which the binding posts are mounted forms with the two collector posts a substantial heat sink. This copper slab is insulated from the panel but is connected to the collector circuit. As mentioned under "Connections to Transistors", the copper and the brass nickel plated posts form the connection means to the power or signal transistors, aside from the 2 small sockets. When making connections to base, emitter or tetrode posts with bare leads, the operator should check to be sure these leads are spaced from the heat sink bar for insulation.

Buried in the copper on the under side is a socket for power transistors similar to the 2N457. Such transistors fit flush on the copper slab with the emitter and base wires on pins inserted in the two small holes marked "E" and "B" between the collector posts. Clamps fit under these two posts to hold the unit tight against the copper. Refer to the section entitled "Connections to Transistors".

THE INTERLOCKS:

To avoid overloads to transistors, instruments and analyzer components, circuit and switching interlocks are included in this device. On each position of the Input Switch, the impedance of the input supply is changed to provide as far as practical a constant current input supply regardless of emitter or base resistance. When the "Input Volts" lever switch is indexed to the "Reach Thru" position, the input (emitter) circuit is automatically opened regardless of the position of the Input Current switch. When the "I_{co}" lever switch is moved from its "RET" or Return position, the input circuit is automatically opened, regardless of the position of the Collector switch, thus affording instant entry of the sensitive I_{co} meter into the Collector circuit

without any possibility of overload, even if the transistor under test had just previously been operating at 15 amperes collector current. The switching sequence is such that the emitter or base circuit is opened before the microammeter is connected into the collector circuit. Conversely, the microammeter is removed from the collector circuit before the input supply is connected restoring full collector current thru the collector ammeter when this switch is returned to the RET position.

THE WARNING LIGHTS:

Switching transients of very short duration can damage or destroy transistors, a condition not usual with vacuum tubes. Protective circuits have been designed into this analyzer to prevent such damaging conditions, with indicators in the form of caution lights for operator observation. Directly to the right of the Input Current Meter is a yellow light which comes on when any potential appears from the input supply. This light is extinguished when the Input Control is turned to the off or extreme counter-clockwise position.

To the immediate left of the Collector Current Meter is a second yellow light. This is illuminated when the Collector circuit is energized. This light is extinguished when the collector variac is turned to the off of extreme counter-clockwise position. These two indicators are very important to the operation of the Analyzer. Whenever connections are changed at the transistor terminals or whenever the configuration switch and the PNP-NPN switch are touched, the lights should be out. Also, when changing current ranges on either Input or Collector switches it is advisable to have the lamps extinguished. This procedure protects the transistor at all times. The operator should get in the habit of returning both controls to the off position, and "running up from zero" watching the three meters.

PRECAUTION: DO NOT HANDLE CONNECTIONS OR INSERT OR REMOVE TRANSISTORS OR DIODES FROM SOCKETS WHEN LIGHTS ARE ON.

The third warning light is red and of a smaller size. It is located to the upper right of the "Collector Volts" switch. This is connected to an interlock circuit between the Collector Current and Collector voltage switch. When the current switch is indexed to any current range over 300 milliamperes, and at the same time the collector voltage switch is indexed to any potential range from 30 to 120 volts, this light will be illuminated. For example, to assume the current switch is indexed to the 10 ampere position, and the collector voltage switch to the 60 volts position, this power requirement of .6 kilowatts would overload the collector transformer and variac. The 10 ampere collector current can just as well be supplied on the 3, 6, or 12 volt range without such a high power requirement. By changing the "Collector Volts" switch to one of the lower voltage positions, the light will be extinguished. If on the other hand, a higher potential is required, the "Collector Volts" switch may be left in the 30, 60 or 120 volt position and the Collector Current switch indexed to the 100 ma, 30 ma, 10 ma or lower current position, where also the warning light will go out.

PRECAUTION: DO NOT PROCEED WITH TRANSISTOR OR DIODE MEASUREMENTS WHEN THIS LIGHT GLOWS RED.

DIRECT READING DC BETA, h_{FE}

A short cut which eliminates the I_C/I_B division may be used for a great number of signal or low power transistors. Before proceeding with the test in this manner, you should familiarize yourselves with the markings on the meters and the panel which are applicable to the direct reading dc Beta test.

You will note on the Input Current Meter, an arrow pointing to the number 10 on the 0-30 scale, and indicating "Set DC Beta". To correspond with this marking, glance now to the Input Range Switch, and below the 300 μ A range note the marking DC BETA— h_{FE} . Now refer to the Collector side of the 3490-A. On the Collector Current Meter you will note under the scales, "Read DC Beta", and along the right hand side of the Collector Range Selector you will note the markings DC BETA— h_{FE} bracketing five of the ranges, with numbers between the current range values and the bracket.

To set up the transistor to read direct DC Beta make sure the PNP-NPN lever is in the correct position,

and the configuration lever is in the COMMON EMITTER position. Set the Collector Volts switch to desired voltage range and adjust the Collector Control until that voltage appears on the voltmeter. Index the Input Range Selector to the 300 μ A position, and the Collector Current Selector in the .1A position. Slowly increase the Input control and adjust the display on the Input Meter to the "Set DC Beta" mark on the meter. Now observe the Collector Current Meter. If there is little or no deflection on this meter, switch down to the 30 mA range, and so forth down to the place where you are getting a good upscale deflection on this meter. Check the Collector Voltmeter and Input Meter and adjust if necessary. Make the DC Beta reading directly on the Collector Current Meter, referring to the position the selector is indexed to. The number inside the bracket indicates the full scale DC Beta for that position. If the Collector Selector was indexed to the 10 mA position, the full scale Beta would be 100. If the pointer on this meter read 8.4 mA, direct DC Beta would be 84.

MEASURING SATURATION VOLTAGE AND RESISTANCE

The saturation voltage $V_{CE\text{ Sat}}$ is measured in the Common Emitter configuration, and is the minimum voltage that will produce full collector current with the transistor current saturated. Index the NPN-PNP switch correctly. Refer to the transistor manufacturer's specification sheet for the input and collector current ratings for saturation tests. Index the input and collector current switches correctly. Be sure all warning lights are out. Index the Collector Voltage switch to the 1.2 volt position. Rotate the input control to increase the input or base current to the rated value as read on the input meter. Holding the base current constant, slowly apply

a small amount of collector voltage until the collector current comes up to the listed value. Read the Saturation Voltage, $V_{CE\text{ Sat}}$ on the central meter. For example, the type 2N457 transistor has a handbook listing of 5 amperes, collector current and 1 ampere base current, and under these conditions, the $V_{CE\text{ Sat}}$ should not be over 1 volt. In the example we will assume a reading of .64 volts.

The Saturation Resistance can readily be determined by dividing the $V_{CE\text{ Sat}}$ by I_C , the collector current. In the example above, $V_{CE\text{ Sat}}/I_C = .64/5 = .128$ ohm for R_{sat} .

MEASURING REACH THRU:

Reach Thru, sometimes referred to as "punch-thru", is a measure of the limit of emitter control with increasing collector potential. As the collector voltage V_{CB} is increased, V_{EB} , the emitter to base will remain at a fixed low value in the millivolt region until the reach-thru voltage is reached. This effect of collector voltage on the emitter is caused by the spreading of the depletion layer into the emitter junction under the pressure of the increasing collector voltage. At the reach thru potential, the emitter to base voltage will suddenly start to increase linearly with increasing collector voltage, a signal that the reach-thru value has been exceeded. This is an important test since it will tell the operator the V_{CB} that should not be exceeded if normal input control is to be expected.

To make this measurement, first be sure all warning lights are out. Connect the transistor and index the NPN-PNP switch correctly. Set the configuration switch to "Common Base" position. Examine the manufacturer's data to see if the reach-thru potential is listed. Since this is a limit value, there is no great reason to run all transistors to the limit value, and therefore, if the transistor is being used at 6 volts or 9 volts in a particular application, measurements up to or somewhat above these values will be entirely sufficient.

Set the Collector Volts switch to the 12 volt position.

Rotate the Collector control clockwise until the center meter indicates full scale, or 12 volts. There is a small index line on the collector control knob, that normally lines up with the panel index line at the off position. This line will now be to the right of the shaft center, at about the 3 o'clock position. Note where it is for the twelve volt reading. Return the control to zero so that the collector warning light is extinguished. Index the Input Volts switch to the Reach-Thru position. Rotate the collector control slowly clockwise to apply the collector voltage. As this potential is applied, the center meter will read "emitter floating potential" at a sensitivity of 1.2 volts full scale. For most small or low power transistors, the floating potential will come up to forty or fifty millivolts, and will hold steady as the collector voltage is increased. If there is no punch-thru, or in other words the reach-thru potential is not reached when the collector control is rotated to the position noted before for 12 volts, then the meter reading will remain at approximately the original potential. In general, it should not rise over 10% scale or 120 millivolts during this test. If the reach-thru value is exceeded, the center meter will start up scale following the collector potential as the collector is rotated. When this occurs, the process should be repeated and the collector control stopped at the point where the meter reading or floating

starts to increase. Then index the Input Volts switch back to the RET (return) position. The center meter will now read the reach-thru voltage of the transistor. It is assumed in making this test at 12 volts that the BV_{CB} or BV_{CE} potential listed for the transistor is greater than 12 volts. If not as is the case with the 2N523, this test must be run at 6 volts or lower. Under no conditions should a reach-thru test be made using collector potentials above the breakdown potential listing.

On power type transistors, the procedure is exactly the same. If the operator plans to use the transistor at 5 volts, a 6 volt punch-thru test is sufficient. If manufacturer's data is available, the test may be made at some other potential up to 12 volts V_C . In general the floating potential of the emitter or the power types may be somewhat higher than on signal units, but the test procedure is just the same.

The question may arise as to how to avoid avalanche breakdown in the transistor should the collector voltage be increased too rapidly when attempting to find reach-thru at collector potentials of 30 volts or above. When the Input Volts lever switch is indexed to the "Reach-Thru" position, a 100 K ohm resistor is in series with the collector circuit, thus limiting the current and avoiding the breakdown.

With reasonable caution and following the procedure outlined above, punch-thru or reach-thru tests can be made without causing any damage to the transistors, and may be repeated when necessary. Occasionally a transistor will not exhibit a sharp break point, but will show increasing emitter floating potential at a fairly low Collector voltage, V_C . In such cases the

reach-thru potential may be considered as the V_C that is required to raise the floating potential to 120 millivolts on the Reach-Thru range. This is equivalent to 5 microamperes of leakage current in the emitter circuit, the greater part of which is caused by collector voltage influence. Other values may be published as new transistors are announced, or more definite information is available on presently available types, but as a general rule to follow where more specific information is not available, the 120 millivolt limit will suffice.

FLOATING POTENTIAL:

The emitter floating potential at any collector voltage level below the punch or reach-thru value may be measured on the central meter. If the voltage on an open-circuited emitter is observed while the collector to base voltage is increased, it will remain within 500 millivolts or less of the base voltage until the reach-thru potential is reached. This test can be made by connecting the transistor with the warning lights extinguished, and a suitable collector voltage range selected, generally under 12 volts. The collector control should be rotated to apply the correct V_C and the index line position of the control noted. Return the collector voltage to zero and extinguish the collector warning light. Index the Input volts switch to the Reach-Thru position. Rotate the collector control back to the previously noted index line position, and read the floating potential on the central meter in terms of 1.2 volts full scale, or 1200 millivolts. The Configuration switch must of course be in the Common Base position for these measurements.

TETRODE TRANSISTORS:

Tetrode transistors, primarily used in RF amplifiers up to 200 megacycles, and as mixers and oscillators require 3 separate and independent power supplies for test measurements. This analyzer is so equipped to handle these types. Examples of these transistors are the 3N36 and 3N37.

Tetrodes are equipped with a second base connection to which an interbase potential is applied. This reduces the base spreading resistance, R_B creating the equivalent effect of reduced cross section base region improving greatly the useful frequency of the unit. The so called "cross base bias" creates an electric field which compresses the active base region reducing the high frequency base resistance. Improvements of 10 to 1 are not uncommon in comparing the tetrode with a triode.

The tetrode or second base voltage supply is brought out to the red binding on the copper heat sink. The voltage control is directly to the left of the Collector Volts switch, and marked Tetrode Volts. This control is calibrated in volts from zero to 10.

Note the transistor type and index the NPN-PNP Switch accordingly. For alpha measurements, index the configuration switch to Common Base. Note the value of emitter current, and set both Input and Collector current switches to the same range. For the type 3N36 as an example, I_E is listed as -1.5 ma so the current switches should both be set to the 3 ma range. Note the listed collector voltage and set the Collector Volts switch to the required range. In the case of the refer-

enced transistor, this is 5 volts. Be sure all warning lights are out. Plug in or otherwise connect the transistor, and apply the correct collector potential.

Rotate the Input control to bring the emitter current to the correct value and note the collector current Alpha under these conditions is the collector current divided by the emitter current. Slowly rotate the Tetrode Volts control up to the listed value. For the 3N36 this is -2 volts. Note the automatic gain control effect on the alpha value.

This same test may be repeated under Common Emitter conditions. Extinguish all warning lights and index the tetrode volts to zero. Set the Input and Collector current switches for beta measurements. In the case of the 3N36, a suitable collector range is 10 ma and input range is 300 ua. Apply a collector potential again of 5 volts and then apply input current to bring the collector current to 5 ma as a suggested figure. Note the dc beta. Slowly apply tetrode volts and observe the effect on the collector current and the resultant h_{FE} . For the 3N36 this should be limited to 2 volts.

AC Beta or h_{re} may also be measured and the automatic gain control of the tetrode or second base observed. Return the tetrode volts to zero, switch to the Beta Set position and thence to the 300 range. Note the reading and then slowly increase the tetrode volts to the 2 volt potential.

Since all potentials are continuously variable and complete current and beta coverage is included in this Analyzer, curves showing one variable as a function

of any of the others can be quickly and easily plotted. Efficient high frequency amplifiers with wide range

coverage and smooth automatic gain control are quite practical with tetrode transistors.

TESTING DIODES AND RECTIFIERS

Information:

Locate the type number of the diode in one of the data books available from manufacturers. Note the polarity or direction of Current flow as usually indicated by an arrow. Note also the rated average forward current, the PIV, or peak inverse voltage, and the leakage current maximum at the peak inverse voltage.

On the larger power types with forward average current ratings over 3 amperes, it may be advisable to clamp the rectifier to the heavy brass posts on the copper slab if full current is to be applied for any considerable length of time. On many rectifiers in this class, the mounting stud can be inserted through the hole in the post.

Note the average forward current, and set the collector current switch to handle this value. Index the configuration switch to Common Base position, and the Collector Volts switch to 3 volts. Be sure all of the special purpose switches are in the RET position, and all warning lights are out.

TESTING DIODES:

Index the left hand lever switch to NPN. Connect the diode between the heavy collector and the base binding posts, with direction of normal or forward current flow from collector to base terminals. In the NPN switch position the collector terminals are positive. Rotate the collector control slowly watching the collector ammeter. If the forward resistance of the diode is low, this meter will start up scale. Keep increasing the collector current up to the listed average value. The full-load Forward Voltage Drop will be indicated by the center meter. For many germanium and silicon diodes in normal operating condition, this will be in the order of .3 to .5 volt.

If there is no apparent current, the diode may be open, or it may be connected in the reverse direction. To determine which is the case, return the collector control to zero extinguishing the warning light. Shift the polarity switch to the PNP position. Slowly rotate the collector control. If the collector current meter deflects up scale and can be brought to the average rated full load current, then the diode was reverse connected. On the other hand, if no current deflection is noted on either the NPN or PNP positions, then the diode is open circuited.

After determining the full load forward voltage drop, return the collector control to zero, extinguishing the warning light. Shift the polarity switch from the NPN position where the forward current was applied to the PNP position. Note the rated PIV, peak inverse voltage and index the collector voltage switch to encompass this value. For example, a 1N1093 computer diode is listed with a reverse working voltage of 15 volts. In this case set the Collector Voltage switch to 30 volts. Rotate the collector control to bring the pointer of the collector voltmeter up to the listed potential. There should be no deflection on the collector current meter. In the example just mentioned this meter would be operating on the .1 ampere range since the average anode current for this diode is 50 ma. If the current meter de-

flects up scale, then the diode has broken down in the reverse direction, and can not be used at the normal reverse potential. Normally there will be no appreciable current indication, and the $I_{CO}-I_{CEO}$ switch may be shifted down through the current ranges until a readable deflection is noted. This is the leakage current at the reverse working voltage, sometimes referred to as the reverse current. For the 1N1093 this should be less than 75 μA at 15 volts. Some manufacturers list other reverse current values at potentials considerably below the peak inverse voltage or continuous reverse working voltage. For example, a second value of 25 μA at 5 volts is specified for this same diode. In all cases, the leakage or reverse current should be less than the manufacturer's maximum. Return the $I_{CO}-I_{CEO}$ switch to the RET position before proceeding with any other steps. Return the collector voltage to zero extinguishing the collector warning lamp.

Where peak inverse or reverse working potentials are encountered higher than 120 volts, measurements will have to be confined to this potential since this is the maximum available in the Analyzer. Under some low line voltage conditions, this may be closer to 110V.

There are many types, kinds and varieties of diodes where the operator will be interested in additional tests. In some instances curve data may be valuable to pin point break points in the characteristics. By studying the description of the controls and following the test procedures already described he can work out for himself other procedures and measurements that will be of considerable value in the study of semi-conductors.

TESTING RECTIFIERS:

Rectifiers are checked, measured, and tested in about the same manner as diodes, except that in general the working current values are higher. As mentioned in the second paragraph under "Information", heat sink considerations must be taken into account.

Proceed as under Diodes with the Collector current switch set to the correct position for the rated average anode current. Determine which is the cathode and which the anode of the rectifier. On heat sink types where the average anode current is of sufficient amplitude to require conduction cooling of the junction, fasten or clamp the stud or heat sink end to the large collector posts, or against the copper slab. If this happens to be the anode, index the polarity switch to the NPN position for forward conduction tests. On types where this is the cathode, index to the PNP position.

On silicon and germanium rectifiers, the collector voltage switch should be indexed to the 1.2 volt position for forward current tests. In general the threshold voltage is less than half a volt. This range provides the most accurate reading of full load forward voltage drop. Many of these rectifiers and diodes are listed by their manufacturers for minimum and maximum forward current at 1 volt. This can be measured quickly and easily using the 1.2 volt collector position. An example would be the 1N484B High Temperature Diode with its minimum forward current rating of 100 milliamperes at 1 volt.

SELENIUM RECTIFIERS:

Selenium rectifiers do not have as low a forward resistance as germanium and silicon types. Where single discs are being tested or measured, the 3 volt range should still be adequate for full current forward voltage drop. Occasionally it may be necessary to use the 6 volt or the 12 volt range for collector potential. This is especially true of the rated 120 volt stacks which may have a full load forward voltage drop of 6 or 7 volts. In all other respects, the test procedure is the same as for the silicon types.

Copper oxide rectifiers are similar in forward characteristics to selenium. Care should be exercised in testing these units to be sure the peak inverse voltage is not exceeded when measuring reverse current.

MEASUREMENT OF SCR PARAMETERS:

Prior to starting the measurements, become familiar with the parameters of the device to be tested, paying particular attention to the maximum allowable ratings. We will for clarity, actually proceed through the test process for a General Electric type C5U SCR unit.

- (1) Note the maximum voltage and current ratings in the data and be sure these are not exceeded.
- (2) The configuration lever may be placed in the COMMON EMITTER position.
- (3) Make sure all controls are off, and the Input Volts I_{CO} - I_{CEO} , and AC Beta switches are on the RET position.
- (4) In testing these devices, the anode lead will be connected at the "Collector" terminal; the cathode lead will be connected at the "Emitter" terminal; and the gate lead will be connected to the "Base" lead. If the SCR is a stud mounted type, it may be clamped into one of the large heat sink binding posts.
- (5) REVERSE LEAKAGE CURRENT TEST (i_R)—PNP-NPN lever should be placed in the PNP position. Index the Collector Current Switch to range or two higher than Maximum Leakage indicated in data. In the C5U, 10 microamperes is the maximum at 25°C, so the Collector Current Switch may be placed on any of the lower current ranges. The manufacturers data will indicate the voltage at which the test is to be made, in the case of the C5U, the rated PRV or 25 volts is to be applied. Index the Collector Volts Switch to the 30 volt position. Slowly increase the Collector Control until 25 volts appear on the Collector Voltmeter. Shift the I_{CO} lever switch to the 6 MA position and observe the indication on the center meter. If no indication, continue through the several positions as indicated in the leakage current measurement section on page 8 of the Instruction Manual, until a readable indication is observed. For the C5U this will probably be in the neighborhood of two to five microamperes, and as indicated in the data, the maximum for a good SCR is ten microamperes. Switch the I_{CO} lever back to the RET position. Without changing the controls, you may now make the —
- (6) FORWARD LEAKAGE CURRENT TEST (i_S)—by merely switching the NPN-PNP lever to the NPN position. One other thing must be adhered to,

and this is found in the manufacturers data on this test. The specification states 10 microamperes is the maximum forward leakage of a good C5U at the rated V_{BO} (25 volts) WITH A RESISTANCE OF 1000 OHMS ACROSS THE GATE AND CATHODE. At this point place a 1000 ohm resistor between the emitter terminal and the base terminal of the 3490-A. Proceed as in making the previous leakage tests, switching down through the I_{CO} lever switch obtain a leakage reading on the center meter. Return control to zero, and switches to their former position.

- (7) GATE CURRENT TO FIRE IGF—This test involves actually making the SCR fire and observing the current necessary for this. Connect the gate lead of the SCR to the base terminal. Index the NPN-PNP switch to NPN. Look in the manufacturers specifications for the test conditions, and the rated gate current to fire. For the C5U the maximum gate current to fire is 200 microamperes with 6 volt potential applied from cathode to anode, and a load resistor of not more than 100 ohms in the anode circuit. If there is no resistance for the anode circuit specified, it is necessary to calculate the value to use for protection of the SCR, as current rises very sharply when the SCR has fired.

For the C5U place a resistor or 90-100 ohms between these posts. Index the Collector Volts to the 6 volt position, and the Collector Current range switch to .1 Ampere. Index the Input Current Switch to the 300 microampere range, as the maximum gate current required to fire is 200 microamperes. Rotate the Collector Control until 6 volts is indicated on the Collector Volts Meter. Very carefully and slowly rotate the Input Current Control until the SCR fires. When this occurs, the Collector Current Meter will register a sharp deflection. Since the point of current to fire is what is to be determined, it may be read directly on the Input Current Meter in microamperes. If this value is less than 100 microamperes the controls may be returned to zero, and the Input Current Switch indexed to the 100 microamperes position and the test repeated, this time reading the Input Current Meter at 0-100 microamperes. It may be of help to note that prior to the SCR firing, the collector current will increase slightly.

- (8) GATE VOLTAGE TO FIRE (VGF)—Having performed the test for gate firing current, this test will be quite similar, with all of the controls and switches being used in the same manner with the following difference. After rotating the Collector Control and placing the 6 volt potential from anode to cathode, index the Input Volts lever switch to the 12 volt position. Now as above, rotate the Input Current Control until the unit fires. Note the voltage just prior to firing on the center meter. If this is a low value, index the lever to the 1.2 volt position for a higher meter deflection. The maximum voltage is .8V for a good C5U, and the minimum .35V. This voltage will change slightly after the SCR has fired or is in the conductive state. Return controls to zero.

WIRING DIAGRAM, 3490-A TYPE 2

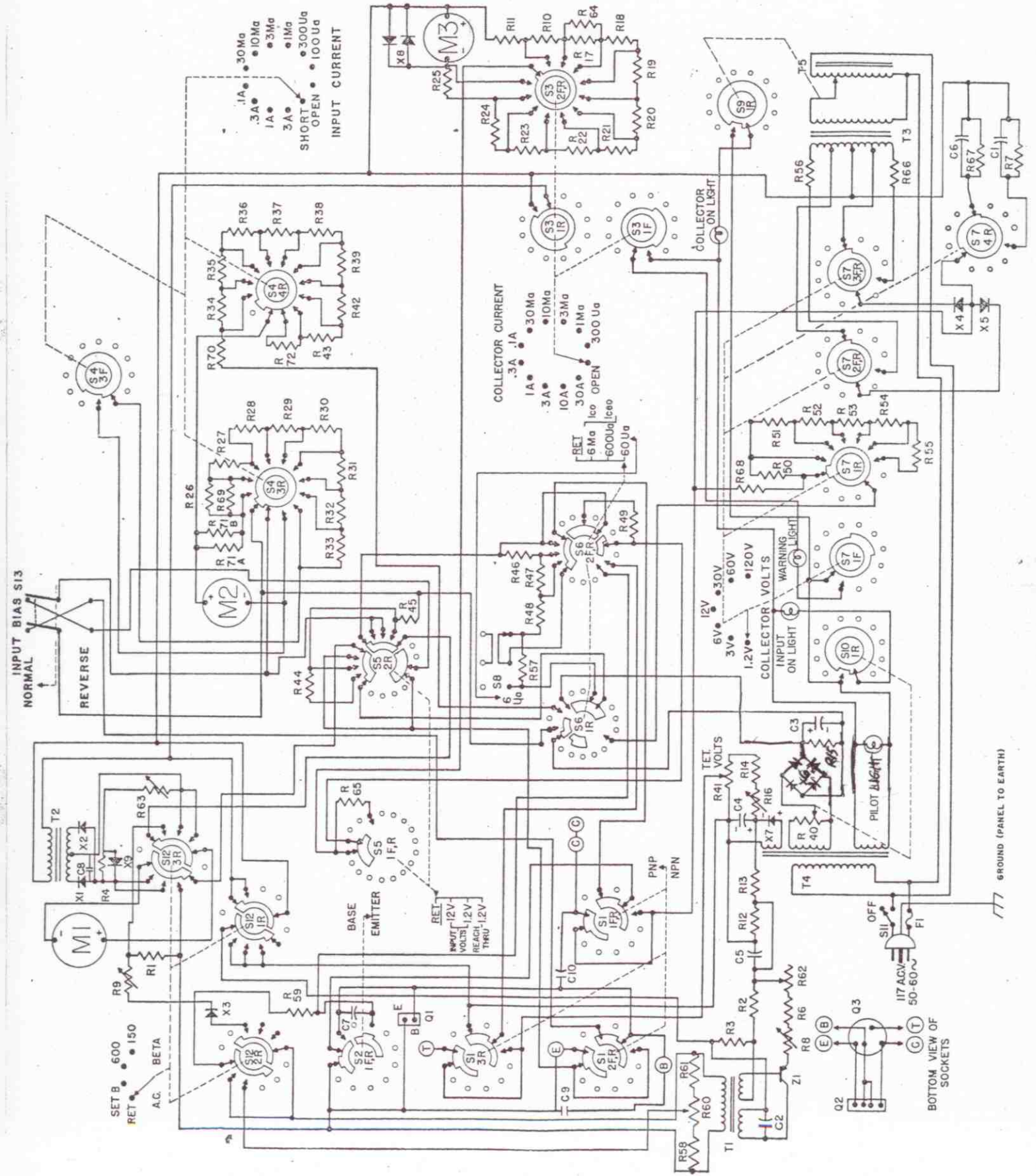

REPLACEABLE PARTS LIST, 3490-A TYPE 2

Ref. No.	Part No.	Req.	Part Name	Description
C1	43-238	1	Capacitor	200 MFD. 150 WVDC
C2	43-125	1	Capacitor	.02 MFD. 600 WVDC, Ceramic Disc.
C3	43-255	1	Capacitor	2000 MFD. 15 WVDC
C4	43-240	1	Capacitor	20 MFD. 150 WVDC
C5	43-108	1	Capacitor	.5 MFD. 200 WVDC
C6	43-245	1	Capacitor	6000 MFD. 15 WVDC
C7	43-254	1	Capacitor	0.1 MFD. 15 WVDC
C8	43-168	1	Capacitor	.001 MFD
C9	43-223	1	Capacitor	330 PF 1000 WVDC
C10	43-224	1	Capacitor	560 PF 1000 WVDC
F1	3207-20	1	Fuse	3 Amp, 8 Ag
	3207-19	1	Fuse Holder	
L1, 2, 3, 4	67-99	4	Lamps	Pilot, 6 Volts, (Bayonet Base)
M1	52-1748	1	Instrument	420, 5UA, Adjust to 50,000 ohms
M2	52-1708	1	Instrument	420, 100UA, Adjust to 1000 ohms
M3	52-1710	1	Instrument	420, 200UA, Adjust to 500 ohms
Q1	2455-232	1	Socket	Power Transistor
Q2	2455-223	1	Socket	4 Pin Transistor, Rectangular, with Retainer Ring
Q3	2455-221	1	Socket	4 Pin Transistor, Round,
R1	T-15-1180	1	Resistor	7K ohm $\pm 1\%$, $\frac{1}{2}$ Watt, Film Type
R2	T-15-1179	1	Resistor	1500 ohm $\pm 1\%$, $\frac{1}{2}$ Watt, Film Type
R3	T-15-1487	1	Resistor	47K ohm $\pm 5\%$, $\frac{1}{2}$ Watt, Composition
R4	15-5055	1	Resistor	3K ohm $\pm 5\%$, $\frac{1}{2}$ Watt, Film Type
R6	T-15-2429	1	Resistor	530 ohm $\pm 1\%$, $\frac{1}{2}$ Watt, Film Type
R7	T-15-2306	1	Resistor	5.6K ohm $\pm 10\%$, 2 Watt, Composition
R8	16-122	1	Resistor	750 ohm Variable
R9, 63	16-161	2	Resistors	10K ohm Variable, WIRT
R10	90-650	1	Shunt Assem.	10 Amp
R11	90-651	1	Shunt Assem.	30 Amp
R12	T-15-1009	1	Resistor	5K ohm $\pm 1\%$, $\frac{1}{2}$ Watt, Film Type
R13	15-3343	1	Resistor	22K ohm $\pm \frac{1}{2}\%$, $\frac{1}{2}$ Watt, Film Type
R14	15-1964	1	Resistor	16.2K ohm $\pm 1\%$, $\frac{1}{2}$ Watt, Film Type
R15	15-217	1	Resistor	510 ohm $\pm 5\%$, $\frac{1}{2}$ Watt, Composition
R16	T-16-90	1	Resistor	3500 ohm Variable
R17, 64	15-3456	2	Resistors	.14 ohm $\pm \frac{1}{2}\%$, Wirewound
R18, 26, 69	15-3215	3	Resistors	.2 ohm $\pm \frac{1}{2}\%$, Wirewound
R19	15-3381	1	Resistor	.7 ohm $\pm \frac{1}{2}\%$, Wirewound
R20	15-3043	1	Resistor	2 ohm $\pm \frac{1}{2}\%$, Wirewound
R21	T-15-2058	1	Resistor	7 ohm $\pm \frac{1}{2}\%$, Wirewound
R22	15-3045	1	Resistor	20 ohm $\pm \frac{1}{2}\%$, $\frac{1}{2}$ Watt, Film Type
R23	15-3363	1	Resistor	70 ohm $\pm \frac{1}{2}\%$, $\frac{1}{2}$ Watt, Film Type
R24	15-3468	1	Resistor	200 ohm $\pm \frac{1}{2}\%$, $\frac{1}{2}$ Watt, Film Type
R25	15-3339	1	Resistor	700 ohm $\pm \frac{1}{2}\%$, $\frac{1}{2}$ Watt, Film Type
R27	15-4191	1	Resistor	.35 ohm $\pm \frac{1}{2}\%$, Wirewound
R28	15-3563	1	Resistor	1 ohm $\pm \frac{1}{2}\%$, Wirewound
R29	15-4198	1	Resistor	3.5 ohm $\pm \frac{1}{2}\%$, Wirewound
R30	15-2059	1	Resistor	10 ohm $\pm \frac{1}{2}\%$, Wirewound
R31	15-3364	1	Resistor	35 ohm $\pm \frac{1}{2}\%$, $\frac{1}{2}$ Watt, Film Type
R32	15-3105	1	Resistor	100 ohm $\pm \frac{1}{2}\%$, $\frac{1}{2}$ Watt, Film Type
R33	15-4199	1	Resistor	350 ohm $\pm \frac{1}{2}\%$, $\frac{1}{2}$ Watt, Film Type
R34	15-4202	1	Resistor	4 ohm $\pm 5\%$, 5 Watt
R35	15-3410	1	Resistor	15 ohm $\pm 5\%$, 5 Watt
R36	15-3344	1	Resistor	60 ohm $\pm 1\%$, 1 Watt, Film Type
R37, 58	15-3336	2	Resistors	220 ohm $\pm 5\%$, $\frac{1}{2}$ Watt, Composition
R38, 61	T-2601- $\frac{1}{2}$ -680	2	Resistors	680 ohm $\pm 10\%$, $\frac{1}{2}$ Watt, Composition
R39	T-2601- $\frac{1}{2}$ -2700	1	Resistor	2.7K ohm $\pm 10\%$, $\frac{1}{2}$ Watt, Composition
R40	16-135	1	Rheostat	25 ohm, 25 Watt, Variable
R41	16-102	1	Rheostat	2.5K ohm $\pm 10\%$, 2 Watt
R42	15-3337	1	Resistor	6.8K ohm $\pm 10\%$, $\frac{1}{2}$ Watt, Composition
R43	T-2601- $\frac{1}{2}$ -27K	1	Resistor	27K ohm $\pm 10\%$, $\frac{1}{2}$ Watt, Composition
R44	15-4192	1	Resistor	2.16 M ohm $\pm \frac{1}{2}\%$, $\frac{1}{2}$ Watt, Film Type
R45, 68	15-4245	2	Resistors	190K ohm $\pm \frac{1}{2}\%$, $\frac{1}{2}$ Watt, Film Type
R46	15-3065	1	Resistor	250 ohm $\pm \frac{1}{2}\%$, $\frac{1}{2}$ Watt

REPLACEABLE PARTS LIST, 3490-A TYPE 2

Ref. No.	Part No.	Req.	Part Name	Description
R47	15-4249	1	Resistor	2250 ohm $\pm 1/2\%$, $1/2$ Watt, Film Type
R48	15-4248	1	Resistor	22.5K ohm $\pm 1/2\%$, $1/2$ Watt, Film Type
R49	T-2601-1-1K	1	Resistor	1K ohm $\pm 10\%$, 1 Watt, Composition
R50	15-3473	1	Resistor	360K $\pm 1/2\%$, $1/2$ Watt, Film Type
R51	15-3474	1	Resistor	600K ohm $\pm 1/2\%$, $1/2$ Watt, Film Type
R52	15-1553	1	Resistor	1.2M ohm $\pm 1/2\%$, $1/2$ Watt, Film Type
R53	15-4194	1	Resistor	3.6M ohm $\pm 1/2\%$, $1/2$ Watt, Film Type
R54	15-4195	1	Resistor	6M ohm $\pm 1/2\%$, $1/2$ Watt, Film Type
R55	15-4196	1	Resistor	12M ohm $\pm 1\%$, $1/2$ Watt, Film Type
R56, 66	15-3167	2	Resistors	20 ohm $\pm 10\%$, 5 Watt
R57	15-3854	1	Resistor	225K ohm $\pm 1/2\%$, $1/2$ Watt, Film Type
R59	15-1061	1	Resistor	200K ohm $\pm 1\%$, $1/2$ Watt, Film Type
R60	16-186	1	Resistor	100 ohm $\pm 20\%$, Variable
R62	16-117	1	Resistor	500 ohm 20%, Variable
R65	15-5007	1	Resistor	100K ohm $\pm 5\%$, $1/2$ Watt, Composition
R67	15-1425	1	Resistor	160 ohm $\pm 10\%$, 1 Watt
R70	15-4203	1	Resistor	1 ohm $\pm 5\%$, 10 Watt OHMITE BROWN DEVIL
R71	15-4200	1	Resistor	.05 ohm $\pm 1/2\%$, Wirewound (Made of two .1 ohm resistors soldered in parallel and calibrated.)
R72	15-3302	1	Resistor	70K $\pm 1\%$, $1/2$ Watt, Composition
S1	22A-379	1	Switch	Lever, PNP-NPN
S2	22A-372	1	Switch	Lever, Common Emitter-Common Base
S3	22A-473	1	Switch	Collector Current
S4	22A-486	1	Switch	Input Current
S5	22A-420	1	Switch	Lever, Input Volts
S6	22A-421	1	Switch	Lever, $I_{CO}-I_{CEO}$
S7	22A-487	1	Switch	Collector Volts
S8	22A-374	1	Switch	Push Button
S9, 10	22A-488	2	Switches	No Detent Single Circuit, Warning Lights
S11	22-116	1	Switch	Toggle, On-Off
S12	22A-377	1	Switch	A. C. Beta
S13	2439-54	1	Switch	Toggle, Reverse Bias
	22-475	1	Switch Assembly	Collector Current, With Resistors
	22-477	1	Switch Assembly	Input Volts, With Resistors
	22-481	1	Switch Assembly	A. C. Beta, With Resistors
	22-489	1	Switch Assembly	Input Current, With Resistors
	22-490	1	Switch Assembly	$I_{CO}-I_{CEO}$, With Resistors
	22-491	1	Switch Assembly	Collector Volts, With Resistors
	22-492	1	Switch Assembly	Push Button, With Resistors
T1	23A-159	1	Transformer	1KC Oscillator Coil
T2	23A-122	1	Transformer	A. C. Beta
T3	23A-158	1	Transformer	Collector Current, 100 W.
T4	23A-176	1	Transformer	Input Current
T5	23A-124	1	Transformer	Variable Powerstat
X1, 2	2250-47	2	Diodes	1N38A
X3, 9	11056	2	Diodes	HD 1441
X4, 5	2250-45	2	Rectifiers	10 Amp Silicon
X6	2250-58	1	Rectifier	Full Wave (Sarkes Tarzian D 52)
X7	2250-55	1	Rectifier	Half Wave
X8	11670A	1	Diode	Meter Protection
Z1	127-1	1	Transistor	2N591
	10A-1642	1	Case	Carrying
	34-72	1	Knob	Round
	34A-73	4	Knobs	Lever
	34-76	2	Knobs	Skirted
	34-77	5	Knobs	Pointer Type
	64A-63	2	Clamps	Transistor, Single
	64A-64	1	Clamp	Transistor, Tandem
	79A-213	1	Lead Assembly	
	2566-51	1	Line Cord	7 ft. long

REPAIR AND SERVICE

The Triplett Electrical Instrument Company suggests when you send your tester in for repair or service you indicate the nature of service required. By supplying this information the Triplett Company or our service stations can serve you better and you will receive your tester back in less time.

TRIPLETT WARRANTY AND CONDITIONS OF SALE

The Triplett Electrical Instrument Company warrants instruments manufactured by it to be free from defective material or factory workmanship and agrees to repair or replace such instruments which under normal use and service, disclose the defect to be the fault of our manufacturing. Our obligation under this warranty is limited to repairing or replacing any instrument or test equipment which proves to be defective, when returned to us transportation prepaid, within ninety (90) days from the date of original purchase.

This warranty does not apply to any of our products which have been repaired or altered by unauthorized persons or service stations in any way so as, in our judgment, to injure their stability or reliability or which have been subject to misuse, negligence, or accident, or which have had the serial number altered, effaced, or removed. Neither does this warranty apply to any of our products which have been connected, installed, or adjusted otherwise than in accordance with the instructions furnished by us. Accessories including all vacuum tubes and batteries not of our manufacture used with this product are not covered by this warranty.

The Triplett Electrical Instrument Company reserves the right to discontinue models at any time, or change specifications or design, without notice and without incurring any obligation.

Upon acceptance of this material the purchaser agrees to assume all liability for any damage and bodily injury which may result from the use or misuse of the material by the purchaser, his employees, or others, and that The Triplett Electrical Instrument Company shall incur no liability for direct or consequential damage of any kind.

Parts will be available for a maximum period of five (5) years after the manufacture of this equipment has been discontinued. Parts include all materials, charts, instructions, diagrams, accessories, et cetera, which were furnished in the standard or special models.

This warranty and conditions of sale are in lieu of all others expressed or implied and no representative or person is authorized to assume for us any other liability in connection with the sale of our products.

The Triplett Electrical Instrument Company

Printed in U.S.A.

Bluffton, Ohio

Part No. 84-164